

WINE RACK 9

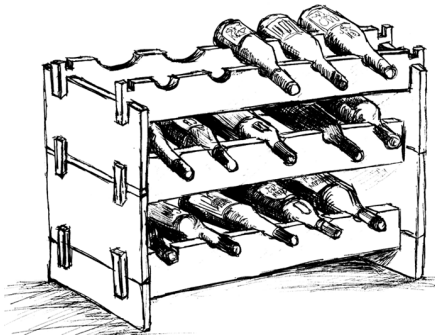

Before purchasing tools, timber and materials, read every step thoroughly then talk to one of our experts

A great looking wine rack that, because of its modular design, can easily be expanded to accommodate a growing wine collection. The components simply lock together and stack one on top of the other as needed.

Step 1: Selecting Materials

We have used radiata pine in this project but the choice of timber is really up to individual taste and could include maple, cedar or Tasmanian oak.

In this project we are using 300mm of 140mm x 20mm for each side panel (except for the base, where the side panels are 70mm x 20mm) and 600mm of 70mm x 20mm for each cross rail.

Step 2: Cutting And Notching

For a three tiered rack measure and cut:

6/600mm lengths of 70mm x 20mm for the rails

2/300mm lengths of 70mm x 20mm for the base side panels

4/300mm lengths of 140mm x 20mm for the second and third tier side panels.

The cross rails and end panels are locked together by a series of notches. Four notches are cut into each cross rail and side panel, except for the base side panels, the bottom and top cross rails (see diagram).

If you intend to add more tiers to the rack in the future you should notch the top rails as you would an intermediate rail.

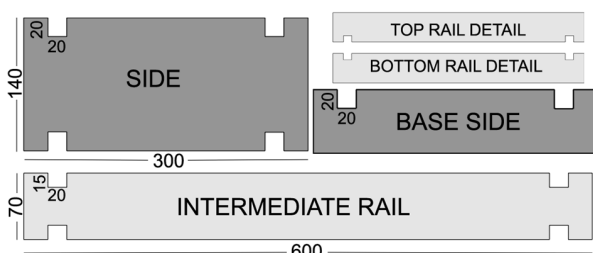

Notches are started 25mm in from the end of the timber and are 20mm wide and 20mm deep for the side pieces and 20mm wide and 15mm deep for the cross rails. If you are using a different thickness timber you will have to adjust these measurements.

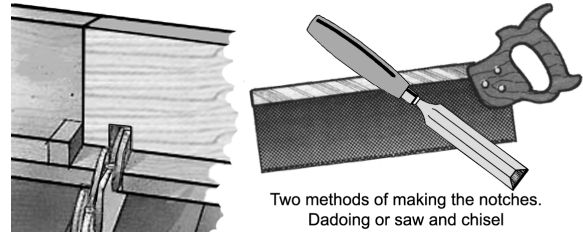

For greatest cutting accuracy a dado cutter and table saw set up would be ideal, but good results can be achieved with a saw and chisel.

When using a dado set, feed all cuts steadily and ensure there is proper support of the material on the saw table. If you have low power equipment, it may be best to dado half depth in one pass, then raise the set in the table saw and complete the full depth in a second pass. Finer splinter control results from slowing the stock feed rate.

When using any power tool you should always wear safety goggles, dust mask and ear protection.

Once all the pieces have been notched you should assemble it to make sure everything fits snugly. Once satisfied, disassemble it and proceed to the next step.

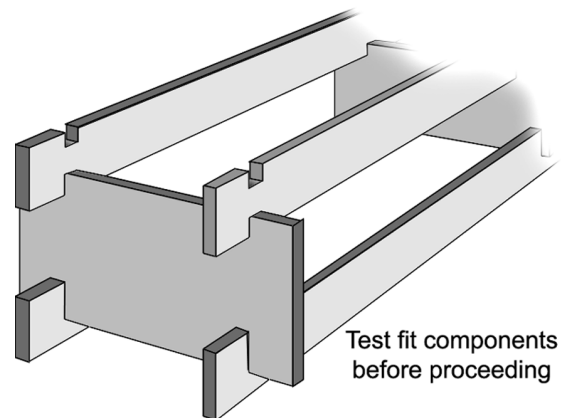

Step3: Cutting Arches

The wine bottles are supported by the front and back cross rails and part circles or arches are cut into each rail to achieve this. The back rail will hold the base of the bottle and will have a large cut-out, while the front rail holds the neck of the bottle and will have a smaller cut-out.

The ideal set-up for cutting the arches would be a drill press with a hole saw attached. Failing that, a hand held power drill and hole saw will still give good results. If you are not confident with, or haven't got, power tools you could still mark out the arches with a compass and do the cutting with a coping saw.

In this project a 100mm diameter hole saw is used for cutting out the back rail arches and a 65mm diameter hole saw is used for the front rail. Generally, these sizes will be suitable, but you may want to experiment with other sizes to cater for your needs.

If using a hole saw, buy the best ones you can afford. Cheap saws overheat quickly and lose their edge even quicker.

The better quality hole saws have three parts consisting of an arbor that attaches to a drill chuck, a pilot bit, and the hole saw itself.

For best cutting results you should lay the rail on a firm flat surface, then butt and clamp an off cut of the same thickness to the working edge of the rail. This will give you a stable surface to cut your holes.

Draw a line horizontally, 25mm from the working edge of the rail ... this will be the depth of the cut-out for your bottles. From the centre of this line, measure up 50mm using a square and mark the point (it will be on the off-cut) ... this will be the centre point of the middle circle you are going to cut. Use this reference point to mark the remaining centre points of the remaining four holes.

You may want to do a test run on a scrap piece of timber before cutting a pre-notched piece. When you're happy, cut the holes for all the back rails

The front rails are treated in much the same manner as the back rails, except you will be using a smaller hole saw. The horizontal centre points of the circles will remain the same, however they will move vertically closer to the working edge of the front rail to retain the 25mm depth of the cut out.

Step 4: Finishing Off

Use an orbital sander or sanding block to clean up all flat surfaces. The ideal tool for the bottle cut-outs would be a drum sander of the appropriate size, but you will still get good results by hand sanding.

Notches should be pretty much left alone as square edges will produce a much better fit.

Depending on the timber you have used you could finish the rack by applying a stain followed by a clear finish, a clear finish by itself or Tung Oil. Regardless of the finish you use, make sure all the pieces are completely dry before final assembly.

Wine Rack Hints

- x When using a hole saw be aware that the exit cut tends to splinter, so take it easy towards the end of the cut. Use the exit cut side for the back faces of the cross rails.
- x When marking out pieces for notching, line up all like pieces together so that you only have to measure and mark some lines once. The same method can be used when marking the centre points for cutting out the arches on the cross rails.
- x Experiment with different sized cut-outs for odd shaped bottles that you store regularly.

Disclaimer:

The Retailer which supplies this information (which includes the authors of this advice and the owner, proprietors and employees) is not responsible for the results of any actions taken on the basis of this information nor for any error or omission in this advice. The Retailer expressly disclaims all and any liability and responsibility in respect of anything done consequent on the whole or any part of this advice.

The recipient of this advice is advised to call a qualified tradesperson such as an electrician, plumber or carpenter where expert services are required.

Building permits may be required and there may be legal requirements or statutory bodies that need to be followed in the implementation of this advice. All such permits and requirements are the responsibility of the recipient of this advice.

© Copyright Hardware & Building Traders Pty Limited

WB&B